

■ SYSTEM SUPPORT UNIT (SSU)

The System Support Unit serves as the database server for all data related to an Encelium system installed in a facility. The SSU stores all system settings and parameters, including attributes for zones, fixtures, sensors, zone controllers and scene controllers. Additionally, it maintains multiple set-points, including those for light levels, time schedules, occupancy sensor timeouts and demand response or load shedding features. The SSU also logs historical data regarding the system's operational and energy savings results.

The SSU provides the ability to remotely access a system in order to change system settings or configuration, analyze system performance or energy data or troubleshoot thereby providing quick and seamless customer support. The SSU also hosts the web interface required for the web enabled Personal Control Software. In addition, optional building automation system interfaces such as BACnet, A/V Interface, Niagara and Lonworks are available upon request.

Each Encelium system requires one SSU, typically located in a building's electrical room, mounted with an ECU.

SYSTEM ARCHITECTURE

This illustration shows how each component is easily integrated into the Encelium Energy Control System. Each light fixture, sensor and lighting controller is daisy-chained back to the Energy Control Unit (ECU) using prefabricated 'click & go' GreenBus™ communication cabling. ECUs typically control individual floors and are linked via an Ethernet Network. Internet or LAN connection allows Windows floor plan based control software to be operated anywhere on the network. For reference, the component shown on this data sheet is highlighted. ■



CONNECTIONS

Typical wall mounting of ECU with SSU, Ethernet Switch and Power Bar.

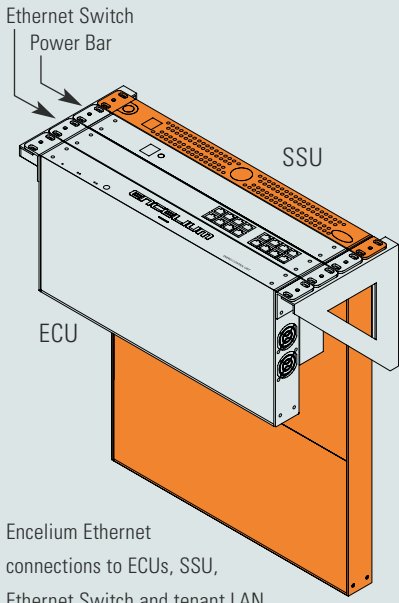

Encelium Ethernet connections to ECUs, SSU, Ethernet Switch and tenant LAN.

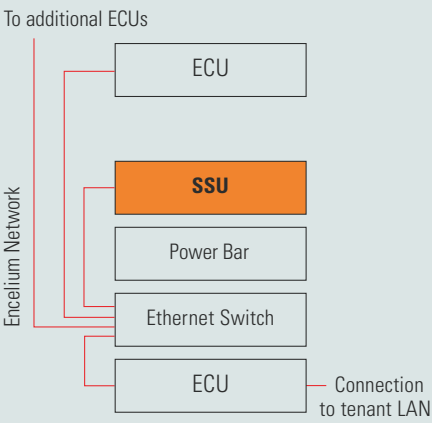

GENERAL

- Pentium Class Processor
- Windows XP Pro Operating System

CHASSIS

- 1U rack height (1.68" H x 16.7" W x 21.5" D w/o bezel, 22.8" w/bezel)
- Max weight 27 lb./ 12.27 kg
- For mounting on standard 19" rack (1U width), individual wall mount or optional
- 4U wall mounted rack.

POWER

- 1 x 280W (non-redundant)
- Auto-ranging 110/220 Volts

ENVIRONMENTAL

- Operating Temperature: 10°C to 35°C (50°F to 95°F)
- Operating Relative Humidity: 20% to 80% (non-condensing), gradient: 10% per hour
- Operating Maximum Vibration: 3Hz - 200Hz at 0.25G
- Operating Maximum Shock: 31G at 2.6ms

REGULATORY

- FCC (U.S. only) Class A
- DOC (Canada) Class A
- UL 60950
- CAN/CSA-C22.2 No. 60950

Specifications subject to change without notice.
Install in accordance with all applicable national and local electrical and building codes.

Cat. # SSU-200



CORPORATE HEAD OFFICE
500 Frank W. Burr Boulevard
Floor 1, Suite 29
Teaneck, NJ 07666 U.S.A.
Tel. 1.201.928.2400
Tel. 1.201.928.4028

CANADIAN OFFICE
68 Leek Crescent - Unit A
Richmond Hill, ON L4B 1H1
CANADA
Tel. 1.905.731.7678
Tel. 1.905.731.1401

TECHNICAL SUPPORT
1.888.531.7573

EMAIL technicalsupport@encelium.com
WEB www.encelium.com/technicalsupport