

SYSTEM ARCHITECTURE

This illustration shows how each component is easily integrated into the Encelium Energy Control System. Each light fixture, sensor and lighting controller is daisy-chained back to the Energy control Unit (ECU) using prefabricated “click & go” GreenBus™ communication cabling. ECUs typically control individual floors and are linked via an Ethernet Network. Internet or LAN connection allows Windows floor plan based control software to be operated anywhere on the network. For reference, the component shown on this data sheet is highlighted. ■



■ UNIVERSAL INPUT/OUTPUT MODULE (I/O MODULE)

The Encelium Universal Input/Output Module is a key component of the Encelium ECS system. This device provides an interface between lighting components such as ballasts, contact closures, occupancy sensors and photo sensors to the Encelium GreenBus™ communication network. The I/O Module automatically detects and addresses the type of device to which it is wired and establishes two-way communication between the Encelium Energy Control Unit (ECU) and itself. Individually addressable, the I/O Module enables each lighting component to be independently controlled and configured to best meet the needs of the facility.

When connected to a ballast, the I/O Module can switch a fixture on or off via a relay contained in the module as well as deliver a low voltage dimming signal to any conventional 0-10V dimming ballast. When wired to an occupancy sensor or photocell, the I/O Module provides power to operate the device and relays sensor information from the device to Encelium’s Energy Control Unit. I/O Modules can also be connected to power relays or switch packs in order to switch larger electrical loads. The I/O Module is easily mounted to a fixture or electrical junction box using a wire nut affixed to a threaded base.

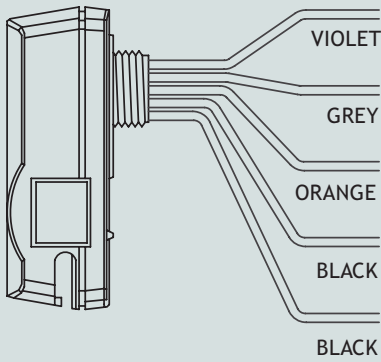

ENCELIUM I/O MODULE

WIRING TABLE

BALLAST	OCCUPANCY SENSOR	PHOTO SENSOR	LENGTH
CLASS II, Low Voltage, 0-10 VDC, 25mA max.	Class II, Low Voltage, 12-24VDC, 40mA max.	Class II, Low Voltage, 10VDC, 25mA max.	36"
CLASSII, Low Voltage Return/Common	CLASS II, Low Voltage Return/Common	CLASSII, Low Voltage Return/Common	36"
Not Used	Class II, Low Voltage Signal	Class II, Low Voltage Signal	7"
Line IN/OUT – Relay Contact	Not Used	Not Used	12"
Line IN/OUT – Relay Contact	Not Used	Not Used	12"

MOUNTING DETAIL

The mechanical construction allows simple installation in existing **Lighting Fixture** knockouts. **GreenBus™** communication wiring is accessible outside the fixture, while all necessary ballast wiring is available inside. The module is cULus listed and all wiring is rated 600V, 105° C for general electrical use.

Occupancy Sensors can be mounted directly to the underside of ceiling tile; an electrical junction box provides a convenient wiring cavity and I/O Module mounting point. The module supplies low voltage power to common sensors eliminating the need for power packs and associated line voltage wiring.

Photo Sensors are mounted directly over work surfaces to measure usable light. The sensors are mounted in the same fashion as the occupancy sensors.

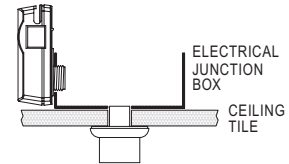
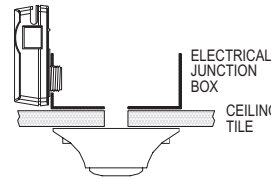
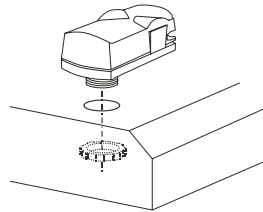

SPECIFICATIONS

- Dimensions: 1.12”H X 1.52” W X 3.19” L
- Max. ambient temperature +40°C/104°F
- Suitable for fixture or junction box mounting in standard 1/2” knockout (7/8” dia.)
- Recommended relay rating: up to 300W 120V-347V for local switching
- Maximum ratings: 6.5A 120V-277V, 4.5A 347V-480V with up to 2 ballasts
- Supplies 12-24VDC, 40mA to sensors
- Two RJ45 connectors for GreenBus™ connection
- Rated for indoor use

Specifications subject to change without notice.

Install in accordance with all applicable national and local electrical and building codes.

Cat. # IOM-302

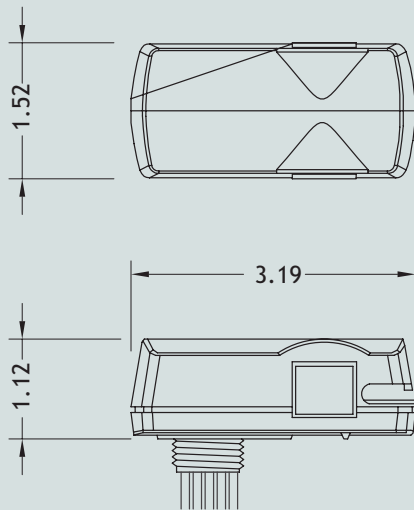

CORPORATE HEAD OFFICE
 500 Frank W. Burr Boulevard
 Floor 1, Suite 29
 Teaneck, NJ 07666 U.S.A.
 Tel. 1.201.928.2400
 Fax. 1.201.928.4028

CANADIAN OFFICE
 68 Leek Crescent - Unit A
 Richmond Hill, ON L4B 1H1
 CANADA
 Tel. 1.905.731.7678
 Fax. 1.905.731.1401

TECHNICAL SUPPORT
 1.888.531.7573

EMAIL technicalsupport@encelium.com
WEB www.encelium.com/technicalsupport