

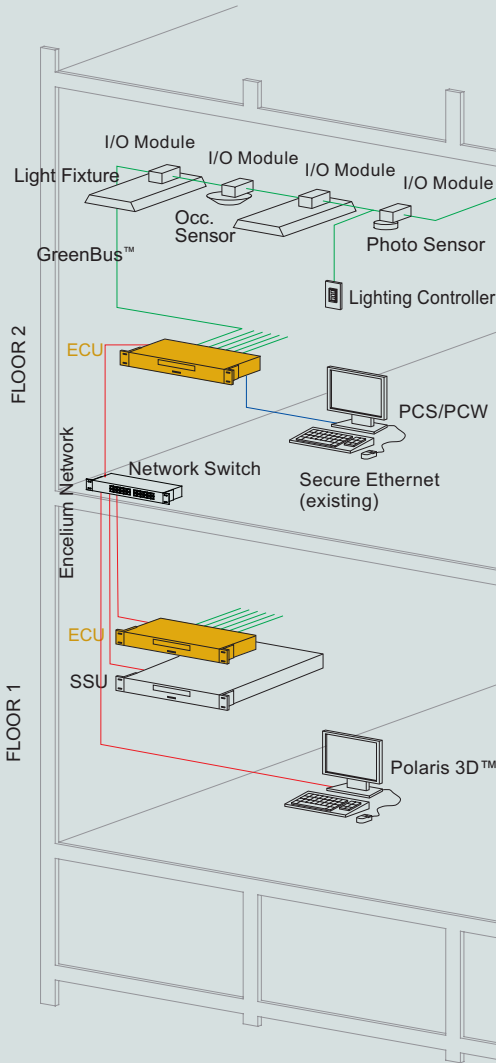

ENCELIUM

ENERGY CONTROL SYSTEM HARDWARE



■ **ENERGY CONTROL UNIT (ECU)**

The ECU is a rack or wall mounted lighting control device that collects, processes and distributes lighting control information to Encelium I/O modules, zone controllers and scene controllers and other devices over Encelium's GreenBus™ network.

Each ECU has 6 GreenBus™ communication channels and can typically control 75 nodes per channel (6 X 75 = 450 nodes in total, representing approximately 25,000 sq. ft. of controlled space).

The ECU is the central intelligence point for the area that it controls, collecting signal information from sensors, zone controllers, scene controllers and personal control software and determining appropriate brightness levels or on/off status for each fixture or zone.

Each ECU has two Ethernet connections. One connection is for communication with other ECUs and the SSU on the Encelium Network. The other Ethernet connection can be used for communication with a facility's or tenant's Local Area Network (LAN) to enable desktop personal control.

ECUs are typically located in the electrical room on each floor of a building and are interconnected using standard Ethernet connections.

SYSTEM ARCHITECTURE

This illustration shows how each component is easily integrated into the Encelium Energy Control System. Each light fixture, sensor and lighting controller is daisy-chained back to the Energy Control Unit (ECU) using prefabricated 'click & go' GreenBus™ communication cabling. ECUs typically control individual floors and are linked via an Ethernet Network. Internet or LAN connection allows Windows floor plan based control software to be operated anywhere on the network. For reference, the component shown on this data sheet is highlighted. ■

GreenBus channels 24
VCD, Class II
GreenBus cable only.
Typically 75
nodes/channel. Do not

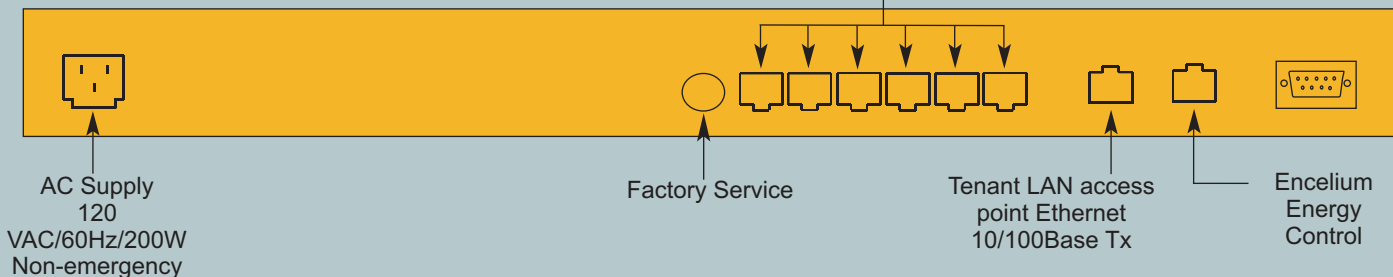

CONNECTIONS

Typical wall mounting of ECU with SSU, Ethernet Switch and Power Bar.

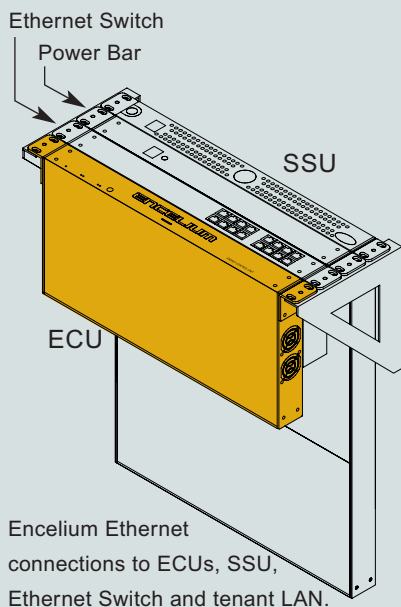

To additional ECUs

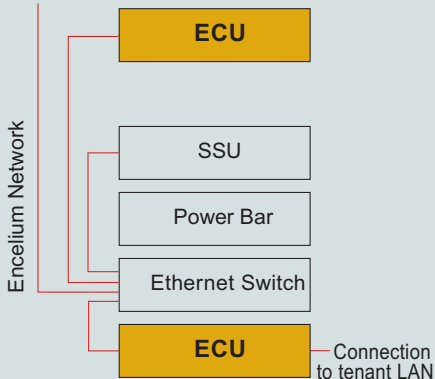

MECHANICAL SPECIFICATIONS

- Dimensions: 18.9" W X 1.7" H X 8.45" D
- Weight: 4.25lbs (1.93kg)
- Max. ambient Temperature +40°C/104°F
- For mounting on standard 19" rack (1U width), individual wall mount or optional 4U wall mounted rack

ELECTRICAL SPECIFICATIONS

- Power Supply; 120V/60Hz/200W
- Normal non-emergency circuit only. Do not connect to UPS or emergency power
- Standard 3 prong AC plug

DATA SPECIFICATIONS

- 6 GreenBus™ channel RJ45 ports with integral 24VDC, Class II
- Tenant LAN Access Point Ethernet 10/100BaseTx Cat. 5 RJ45 port
- Encelium Energy Control Network Cat. 5 port
- Factory Service Link
- Status LED on front of unit
- Configuration stored in non-volatile flash memory

Specifications subject to change without notice.

Install in accordance with all applicable national and local electrical and building codes.

Cat. # ECU-100



CORPORATE HEAD OFFICE
500 Frank W. Burr Boulevard
Floor 1, Suite 29
Teaneck, NJ 07666 U.S.A.
Tel. 1.201.928.2400
Fax. 1.201.928.4028

CANADIAN OFFICE
68 Leek Crescent - Unit A
Richmond Hill, ON L4B 1H1
CANADA
Tel. 1.905.731.7678
Fax. 1.905.731.1401

TECHNICAL SUPPORT
1.888.531.7573

EMAIL technicalsupport@encelium.com
WEB www.encelium.com/technicalsupport